



## The Turbocor Family of Compressors Model TT400

A VFD (Variable Frequency Drive) built in as a standard providing unmatched part-load efficiency.

A permanent magnet motor which cuts size and weight while increasing efficiency.

A fully functional computer to provide control plus high level of monitoring and diagnostics.

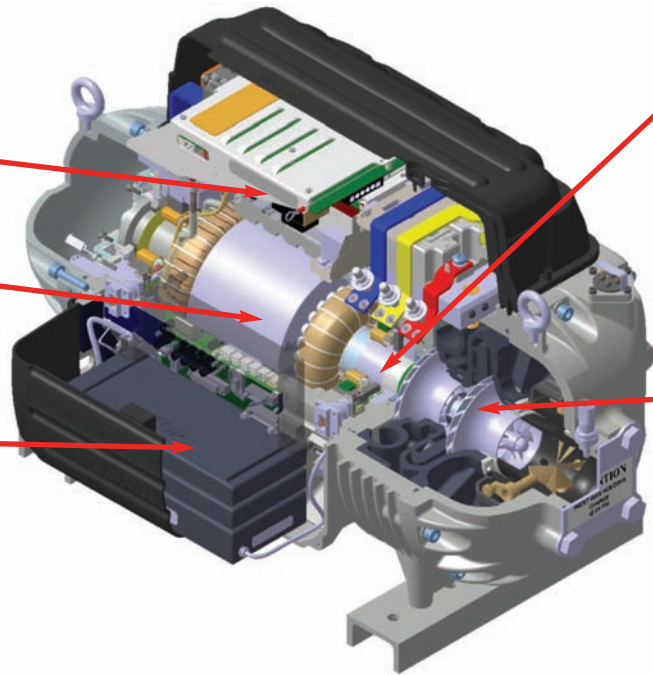

Oil-free magnetic bearings provide quiet and reliable operation. No need for oil, reduces maintenance, and eliminates the complexity, cost and reliability issues of oil-based designs.

Two Stage, Direct Drive, Hermetic Centrifugal compressor with shrouded impellers resulting in high efficiency at full load and extraordinarily high efficiency at part load conditions.

**A 400 to 500 kW nominal capacity compressor that is:**

**50%+ More Efficient:** A compressor 50%+ more efficient than other compressors in its size range. And this exceptional performance can be monitored, either on site or remotely via a state-of-the-art monitoring diagnostics system.

**Totally Oil-Free:** Oil-free operation is something the industry has worked decades to achieve. This *oil-free* design eliminates not only the potential for efficiency robbing oil contamination, but also all of the oil management accessories: oil heaters, oil pumps, oil separators, oil filters, etc., plus oil disposal.

**Extremely Lightweight:** TT400 compressor weighs only 132 kg, approximately 1/8th the weight of conventional compressors. In addition, this compressor only requires about half the space of a traditional compressor.

**Extraordinarily Quiet:** At an operating sound level the compressor is so quiet that, given typical equipment background noise, one literally cannot hear it run.

**Redefines Soft-Start:** The TT400 compressor redefines soft-start, drawing less than 2 amps, compared to 700-800 amps required by conventional compressors using across-the-line starters.

***Making a world of difference***

Visit our website at [www.turbocor.com](http://www.turbocor.com)  
to learn more about this and other Danfoss Turbocor products.

# Unprecedented Energy Efficiency

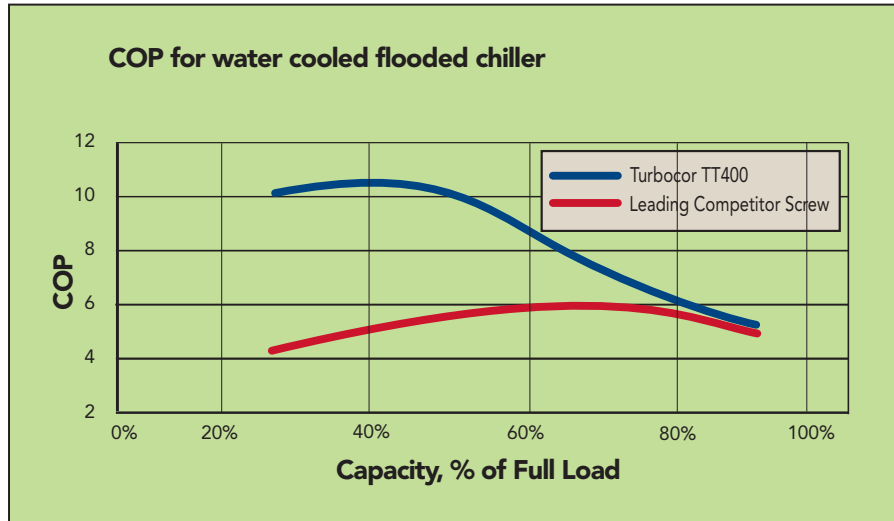

Outstanding energy savings from digitally controlled, frictionless two-stage centrifugal compression means significant reductions in operating cost and environmental emissions associated with energy production.

Chart shows the full and part load performance curve of the Turboçor compressor compared with a typical screw compressor on a 460kWR (130-tonR) water cooled chiller. The integrated part load values (IPLV) yield a 50%+ improvement in many applications.

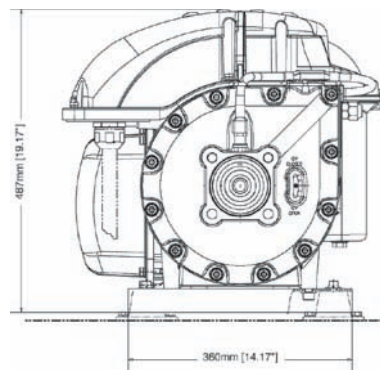
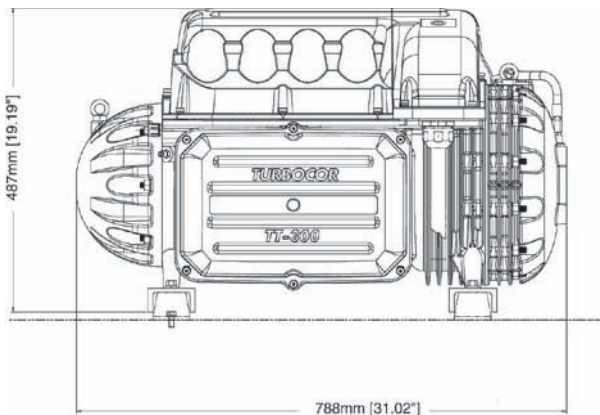

Length	788 mm (31.02")
Width	518 mm (20.40")
Height	487 mm (19.19")
Compressor weight	132 kg (290 lbs)
Refrigerant	R-134a
Sound	70bDA@5'



1769 E. Paul Dirac Drive  
 Tallahassee, FL 32310, USA  
 Phone: +1 (850)-504-4800  
 Fax: +1 (850)-575-2126  
[www.turbocor.com](http://www.turbocor.com)

Danfoss can accept no responsibility for possible errors in catalogues, brochure, and other printed material. Danfoss reserves the right to alter its products without notice. This also applies to products already on order provided that such alterations can be made without subsequent changes being necessary in specification already agreed. All trademarks in the material are property of the respective companies. Danfoss and the Danfoss logo are trademarks of Danfoss A/S. All rights reserved.